

Flexible Working Arrangement toward Organizational Commitment and Work-Family Conflict

Jasmine Lee Mee Choo¹, Nasina Mat Desa^{2*} & Muhammad Hasmi Abu Hassan Asaari²

¹School of Business and Administration, Wawasan Open University, Penang, Malaysia

²School of Distance Education, Universiti Sains Malaysia, Penang, Malaysia

*Correspondence: School of Distance Education, Universiti Sains Malaysia, 11800 Penang, Malaysia. Tel: 604-653-2270. E-mail: nasina@usm.my

Received: December 10, 2015 Accepted: January 6, 2016 Online Published: January 31, 2016

doi:10.5430/sass.v3n1p21 URL: <http://dx.doi.org/10.5430/sass.v3n1p21>

Abstract

The purpose of this paper is to examine the relationship between flexible working arrangements and organizational commitment and work-family conflict. A total of 130 questionnaires were distributed to the finance executives and the returned yielding a response rate of 87%. The results revealed that a flexible working arrangement was significantly and positively related to organizational commitment. It also revealed that a flexible working arrangement was significantly and positively related to work-family conflict. Theoretically, this paper has contributed to the literature on the flexible working arrangement and organizational commitment. Practically, the practitioners of manufacturing companies should consider implementing flexible working policies to cater to the needs of their employees by providing flexi-time, remote working or different working hours. In conclusion, this paper has revealed the importance of flexible working arrangement policies in affecting organizational commitment and work-family conflict.

Keywords: *flexi-time; remote working; different working hours; manufacturing*

1. Introduction

In recent years, organizational commitment had emerged as an interest area of research within the study of organizational psychology (Morrow, 1993; Meyer & Allen, 1997; Adebayo, 2006). According to Salancik (1977), organizational commitment is defined as a psychological state that explains an employee's relationship with the organization together with the implications for the decision to continue membership in the organization. In previous research by Mowday, Steers, and Porter (1979), they developed organizational commitment as construct, which is defined as 'a strong belief in and acceptance of the organization's goals and values, with the willingness to employ considerable effort on behalf of the organization, and have a strong desire to remain in the organization'. Furthermore, Meyer and Allen (1991, 1997) refined this construct into three discrete components of organizational commitment, which are known as affective commitment, continuance commitment and normative commitment. These constructs are further used to address the common concerns among many employers such as poor attendance, high employee turnover and other outcomes. In order for employers to achieve high organizational commitment among their employees, the employers must help their employees to value their involvement in the organization. The more employees feel their value as being part of the organization, more likely they would continue to remain with their employer.

Despite the popularity of organizational commitment as a topic of past researchers, work-family conflict also appears as topic of interest for researchers within the study of organizational psychologists for the past 20 years (Thompson et al., 2006). There has been an increase of interest in the study of work-family conflict, since this topic has a vast impact on organizations, society, and families, as well as individuals themselves. Work-family conflict is defined as the conflict that occurs when employees try to balance work and family responsibilities. Most of the time, employees would experience this type of inter-role conflict when the times spent on work requirements puts the employee in a difficult position to fulfill the requirements of family needs. In order to overcome the work-family conflict, Boyar et

al. (2008) suggested that organizations should adopt family-friendly programs and policies to help their employees to balance between work and family demands.

This paper will discuss how organizations show that they are supporting employees' well-being by offering flexible working arrangements. Furthermore, this study would also explore more on the effects from the relationship of the flexible working arrangement on organizational commitment and work-family conflict. Thus, this paper intends to understand, firstly, the impact of flexible working arrangement policy on employees' organizational commitment and secondly, work-family conflict, specifically in a manufacturing company located in Malaysia. Moreover, it is important for the organization to understand how such flexibility policies affect their employee's organization commitment level as well as their work-family conflict.

2. Problem Statement

Today, Malaysia's manufacturing industry is considered one of the major contributors to its economy, amounting to about 25 percent of Malaysia's GDP. Since the manufacturing industry is a growing industry, many companies especially the multinational companies (MNCs) realized the effects of high organizational commitment that are very important, along with lower level of work-family conflict among their employees. According to Nijhof, de Jong and Beukhof (1998), the success of an organization does not only rely on how the organization utilizes its employees or its human capital, but it also depends on the level of employee commitment to the organization. Higher levels of effort and commitment would lead to higher levels of performance from both the individual and at the organizational level (Salami, 2008).

In the Malaysian context, it is common that current employees, especially those that are part of 'Generation Y' show a trend of hoping from job to job. Younger generations are no longer as loyal when compared to the Baby Boomers, who in contrast would choose to stay longer in an organization. For instance, Generation Y, has grown up in a technological era, and this has effected their social affections. Thus, the up-bringing factor contributes to their lower organizational commitment (Lyons, 2011). Thus, the biggest challenge for Malaysian organizations is to provoke a sense of commitment among the employees and to instill commitment and loyalty to their employees. As Malaysia aims to transform into a high income nation by 2020, it is also crucial for organizations to pay more attention to the issue of organizational commitment. According to Meyer, Paunonen, Gellatly, GoYn, and Jackson (1989), high organizational commitment among the employees would best explain about how the organization optimizes their employees' productivity, leading to such benefits as low absenteeism, higher efficiency and higher production rates.

For many employees, juggling work and family responsibilities have become a common experience in their busy daily lives (Galinsky, Bond, & Friedman, 1993; Lee & Duxbury, 1998). Although engaging in both work and family roles could bring positive effects, if employees are unable to balance well between the responsibilities associated with both roles, then potential work-family conflict would increase (Greenhaus & Beutell, 1985; Frone, Russell, & Cooper, 1992; Netemeyer, Boles, & McMurrian, 1996; Greenhaus & Powell, 2003). Despite the growing media attention and past literature on work-family issues, most of the management found in organizations simply does not know which organizational initiatives actually reduce work-family conflict and how these changes are likely to impact employees and the whole organization (Pitt-Catsoupes, Kossek & Sweet, 2006).

Malaysia is regarded as "one of the most developed countries in the developing world". Thus, as a result of such economic growth, the working conditions in Malaysia had started to mirror those in Western countries. Average working hours per week had increased and Malaysian employees had reported that they had heavier workloads with low compensation of salary. According to Manshor et al. (2003) and Edimansyah et al. (2008), with all these changes, it comes as no surprise that the Malaysian workforce is stressed. Therefore, employers in Malaysia must begin to create and design more family-friendly working environments for their employees. According to Aminah (2007), organizations in Malaysia are still at the early stage of work-family policy development, and such work-family employment practice is still very new and not very common in Malaysia (Subramaniam & Silvaratnam, 2010).

3. Significance

This topic gains its importance from the globally increasingly attention paid to workplace conditions when workers are unable to adequately meet family responsibilities because of their long working hours. This makes workers often feel that meeting family needs could jeopardize their job load. The findings of this paper may be a useful reference for organizations, especially HR managers and policy makers, to contemplate different work arrangement flexibility strategies, in as far as the implications of demonstrating organizational care and support for employees.

Moreover, this paper is expected to contribute to the body of literature related to the relationship between the flexibility of working arrangements to organizational commitment and work-family conflict, that would offer negative or positive implications for all the employees in an organization. The findings of this paper would bring great benefit to the employees, especially in assisting them to realize how flexible working arrangements can help them to strike work life balance. At the same time, being flexible will make employees become more responsive to change, which nurtures them to be more competitive and have the ability to adapt to difficult situations more easily. In summary, this paper would be a significant contribution as a source of input to Malaysian government policy, where the government is now looking into how to tap its own potential human resources.

4. Literature Reviews

4.1 Organizational Commitment

Since the past few decades, the term “organizational commitment” has played an important role in the study of organizational behavior. Becker (1960) was the first academic to conceptualize the organizational commitment term that continuously led to more fruitful academic discussion on this concept in the coming years. According to O’Reilly and Chatman (1986), organizational commitment had been extensively studied due to its role as a core job attitude to govern how employees approach their careers in the organization. Organizational commitment is a psychological obliging force that binds employee to courses of action relevant to the target of the organization (Meyer & Herscovitch, 2001). Employees that have strong organizational commitment will decide to continue their employment with the organization because they choose to do so (Ghani et al., 2004).

Furthermore, Meyer and Allen (1991) expanded the concept of organizational commitment by introducing a three-component model that comprises three components; affective commitment, continuance commitment and normative commitment. Since the three-component model was developed, it has led to new development of organizational commitment and had been in extensive discussion by many academics (Ketchand & Strawser, 2001). For the purpose of this paper, these three components of organizational commitment will be discussed.

4.1.1 Affective Commitment

Affective commitment had persistently been the most desired form of commitment, and the major approach to the study of organizational commitment in relation to organizational outcomes (Meyer et al., 2002). Meyer and Allen (1991) defined affective commitment as “employee’s emotional attachment to, identification with, and involvement in the organization”. According to Meyer and Allen (1991), this term largely comes from the works of Mowday et al. (1979).

Ketchand and Strawser (2001) denotes that most employees will develop affective commitment to the employer if they have shared a common goal at the same time, and they are willing to assist the employer to achieve those goals. Affective commitment is considered the key indicator of the relationship between employee and employers, developed when employees get involved and provide continuity support to achieve value for the organizational (Meyer & Herscovitch, 2001). In short, affective commitment refers to an individual’s desire to be employed with that organization out of his or her emotional attachment (Meyer & Allen, 1991; 1997).

4.1.2 Continuance Commitment

Meyer and Allen (1991) defined continuance commitment as “an awareness of the costs associated with leaving the organization”. Meanwhile, Becker (1960) explained on how an employee would invest in side-bets by wagering on continued employment in an organization, and would lose those side-bets as they choose to leave the organization. Examples of side-bets are including time, status, pensions to be received, employee benefits, specific skills and tenure in the organization (Meyer & Allen, 1984, 1991; Reichers, 1985). Meyer and Herscovitch (2001) explained that those employees who have invested a huge sum of side-bets in an organization would develop strong continuance commitment. Compared to the employees who have acquired or accumulated transferable skills, the continuance of commitment will be lowered. These employees therefore would have a higher possibility to leave the organization for a better position outside the organization (Meyer & Allen, 1984).

Based on the previous review on continuance commitment, Briscoe and Finkelstein (2009) explained that employees possess continuance commitment due to the inconvenience of leaving, as well as due to the perceived cost for leaving organization.

4.1.3 Normative Commitment

Meyer and Allen (1991) defined normative commitment as “a feeling of obligation to continue employment”.

Compared to the other two components of commitment, this normative commitment component has not received a great deal of attention from many academics (Meyer & Allen, 1991; Johnson et al., 2010). Normative commitment or the feelings of obligation does not generate sense of involvement towards the organizations (Meyer & Allen, 1997). Thus, Meyer and Herscovitch (2001) claimed that most employees would only develop normative commitment due to the feeling of obligation and loyalty after receiving benefits from their organization. In short, normative commitment refers to the perceived obligation and loyalty from employees to remain employed in the organization (Meyer & Allen, 1991, 1997; Johnson et al., 2010).

4.2 Work-Family Conflict

The phrase of 'work-family conflict' emerged in the 1980s (Barnett, Gareis, & Brennan, 1999). Work-family conflict is denoted as a form of inter-role conflict which arises due to mutually incompatibility in terms of role at work and family. In the past, researchers have generally neglected the studies on work-family conflict (Netemeyer et al., 1996).

According to Younis, Zulfikar, Arshad and Imran (2011), they also concluded that as the line of separating work obligation and family commitment had gradually blurred, this has resulted employee to encounter the impact of work-family conflict. Greenhaus and Beutell (1985) have suggest examining the pressures that are receive from both work and family roles, as this is fundamental for researchers to have a better understanding on the effects of work and family role pressures. Work-family conflict can increase in a situation where the work interferences acutely with family roles, especially for employees with responsibilities towards being a care-provider. Examples include where a male employee who has just become a father with new born baby, who may want to spend more time with his family, but meanwhile his manager stresses him for project and work deadlines, and at the same time threatens him with termination if the project/work fails. The result would be that this male employee is going to suffer intensified work-family conflict. Perception of work and family as separate entities that compete for attention, time and energy, had led to a constant feeling of tension and conflict (Marks, 1977).

4.3 Flexible Working Arrangement

In the recent years, there is growing strand of research on flexible working arrangements, since there has been a significant indication of positive outcomes for the employee and the organization. Workplace flexibility can be defined as 'the ability of employees to make changes on where, when and the total time they would spend or engage in work-related tasks' (Rau & Hyland, 2002; Hill et al., 2008). Such flexible work practices have become widespread within organizations and are often used as part of the human resource strategy to attract, motivate and retain key talent (Hill et al., 2008). Government also encourages many employers to offer flexible working conditions, like flexi-hours, flexible or remote work places and part-time working options to their employees. In consequence, flexible working options have been offered by employers as the work condition for their employee (Cully et al., 1999; Hogarth et al., 2000).

According to Bond, Thompson, Galinsky and Prottas (2002), the availability of flexible working options are more in demand because there are more dual-earner couples, women and single-parent families, as well as those who have geriatric care responsibilities, in the workplace. Under flexible working conditions, employees are assisted in their control of how they can work in order to mitigate the effects of work stress over their work (Halpern, 2005). Richman (2006) perceived flexibility in working policies, which includes the ability to manage the demand of work and family matters, were strongly related to higher levels of organizational commitment. Meanwhile, other studies found that the availability of the flexibility working arrangements was differentially related to outcomes of affective commitment as well as work-to-family conflict (Thompson, Beauvais & Lyness, 1999). Burud and Tumolo (2004) also concluded that flexible work practices and policies are an indicator of greater employee commitment with lower intentions to leave the company.

Flexible work arrangements, like telework, flexible work hours, and flexible workplaces are often used to help employees in balancing their family and work life (Lim & Teo, 2000). The mere existence of flexible working policies in particular is associated with strong positive outcomes for employees who worked for middle to large size organizations. According to Thomas and Ganster (1995), lower levels of work-family conflict were positively associated with the existence of flexibility support and policies like work schedule flexibility and supportive supervisors. While there is substantial literature review on the relationship between flexible working arrangement and work-family conflict, more evidence has been presented to prove the relationship between flexible working variables can influence outcomes for the individual and the organization, such as stress and work-family conflict (Dunham et al., 1987; Batt & Valcour, 2003; Frye & Breaugh, 2004; Eby et al., 2005; Lapierre & Allen, 2006; Madsen, 2006).

4.4 Relationship between Flexible Working Arrangement and Organizational Commitment

Previous research has concluded how flexible working arrangements in an organization would influence organizational commitment, and generally found a positive relationship between these two variables (Grover & Crocker, 1995; Thompson et al., 1999; Dex & Smith, 2002; Harris & Foster, 2005; Maxwell et al., 2007). There is continuous interest from other researchers to study flexible work as it has been advocated as a means of increasing organizational commitment.

According to Glass and Finley (2002), their study concluded that flexible working arrangement does impacts positively on organizational commitment. Pierce and Newstrom (1980, 1982) compared organizational commitment among those employees with flexible working schedules and those without flexible working schedules and found the former were more committed. Glass and Finley's (2002) review of the literature ratifies these findings, as concluded that flexible work creates favorable impacts on employee's well-being and reducing work-family conflict.

4.5 Relationship between Flexible Working Arrangement and Work-Family Conflict

A growing number of organizations do offer employees flexible work arrangements, and other family-friendly policies that are aimed at helping employees to balance work and family responsibilities (Perrin, 1994). Therefore, flexible working arrangements have been identified as one of the more important means that can be used to balance work and other commitments (Glass & Estes, 1997; Dex & Smith, 2002).

Many researchers have studied the relationship between flexible working arrangement and work-family conflict with little consensus regarding their findings (Allen & Shockley, 2006). For example, in some of the studies, it was explained that flexible work relates to less work-family conflict (Hammer, Allen, & Grigsby, 1997; Hill, Yang, Hawkins, & Ferris, 2004), whereas other studies also reported that there was no relationship between the two variables (Thomas & Ganster, 1995; Galinsky, Bond, & Friedman, 1996; Anderson, Coffey, & Byerly, 2002).

More research is being performed, since this has become a topic of interest for many researchers as well as practitioners, in order to have a better understanding of the relationship between these two variables. Hammer et al. (2005) denotes that workplace practices can help in reducing the employee work-family conflict. In an attempt to reduce family-work conflicts, organizations have adapted by offering flexible working arrangements to their employees (Grover & Crocker, 1995). Almer and Kaplan (2002) examined the relationship between flexible work and work-family conflict, and found flexible work employees displayed a lower level of work-family conflict. Thomas and Ganster (1995) found an indirect positive effect of work flexibility on work-family conflict. An indirect positive effect was found on attitudes, mental and physical health outcomes such as depression, as well as somatic complaints and cholesterol levels, through an increase in employee control and subsequent decrease in work-family conflict.

Based on the literature review on these findings, Glass and Finley's (2002) concluded that flexible working arrangement not only bring favorably impacts on well-being, but also helps to control and reduce work-family conflict. Moreover, perceived work flexibility possesses a great positive effect on work-family conflict by enabling employees to better manage their work and family matters. Work-life literature had reviewed and depicted flexible working arrangements as tools for enhancing work-personal life integration and the reduction of work-family conflict (Kossek & Ozeki, 1998; Friedman & Greenhaus, 2000; Barnett & Hall, 2001; Lewis, Smithson, Cooper, & Dyer, 2002). In particular, flexible work policies and arrangements have been cited as efforts taken by human resource practitioners in helping employees to manage interference between work and family domains (Adams & Jex, 1999; Golden, 2001; Goldenhar, 2003).

4.6 Summary

Thus the theoretical framework of this paper comprises flexible working arrangement as independent variable in relation to organizational commitment and work-family conflict as dependent variables, which are constructed in the framework as depicted in the Figure 1.

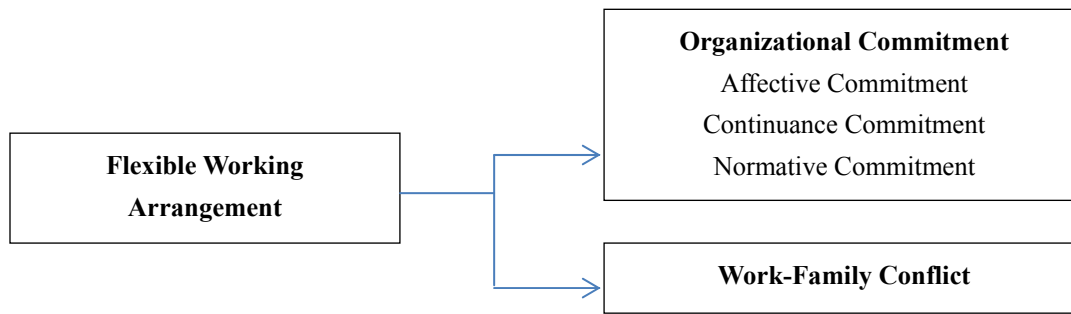

Figure 1. Theoretical Framework

5. Hypotheses

Flexible work schedules demonstrate care and support for the employees. For instance, it can help to accommodate extra organizational obligations that most employees would have to meet in their busy life. Baltes et al. (1999) found that most employees would reciprocate the flexible work schedules in terms of providing positive organizational commitment to the organization. Also, past number of studies has shown that the availability and offering of flexible work policies is positively associated with higher employee commitment (Grover & Crooker, 1995; Roehling et al., 2001; Scandura & Lankau, 1997). Scandura and Lankau (1997) also found that offering flexible work arrangements in an organization is often associated with higher organizational commitment among the employees. As from an organizational perspective, the introduction of flexible working to the employees brought evidence of benefits that include greater employee loyalty and commitment (Grover & Crooker, 1995; Roehling et al., 2001). Therefore,

- H1a: Perceived advantages of flexible working arrangement is positively related to affective commitment
- H1b: Perceived advantages of flexible working arrangement is positively related to continuance commitment
- H1c: Perceived advantages of flexible working arrangement is positively related to normative commitment

In the past research, Galinsky and Johnson (1998) and Hill et al. (1996) concluded that there is often an argument on how flexible working arrangements can contribute positive integration towards work and personal life. Kossek and Ozeki (1999) explained that work-family conflict is a crucial variable that often goes neglected when it comes to understanding the relationship between flexible working arrangements and work-related outcomes.

Glass and Estes (1997) found evidence from the United States that suggests flexible working arrangements are able to reduce employee work-family conflict by increasing employee choice and flexibility options over their work demands. Meanwhile, in Britain, White et al. (2003) also found that in general, flexible work that allows employee discretion in the control of the work finishes and starts is positively associated with reducing work-family conflict among the employees. Therefore,

- H2: Perceived advantages of flexible working arrangement is positively related to work-family conflict

6. Methodology

The quantitative research method was used, which comprises cross-sectional correlation research design. According to Breakwell, Hammond and Fife-Schaw (1995), the cross-sectional correlation research design enables the researcher to observe two or more variables and further describes the relationship between these variables. The survey data is collected through a self-administered structured questionnaire that was designed based on previous literature and has been modified accordingly.

6.1 Population and Sampling Frame

The population of this paper consisted of the finance executives that are currently working in a manufacturing company in Penang, Malaysia, and who work in different finance functional units. These individuals comprise the

sampling frame. The selection this population is due to the finance employees in the manufacturing that implemented flexible working hours as compared to the other finance employees in other sectors in Penang.

6.2 Distribution of Questionnaires

The research questionnaires were distributed to finance executives working in manufacturing company. The questionnaires were distributed to finance executives working in the 6 finance functional units in Penang. A total of 130 questionnaires were distributed.

6.3 Questionnaire Design and Measurement

The questionnaire is comprised four parts of Part A, B, C and D. Part A covered nine questions that gather the information on the demographic profiles of the respondents. All the nine questions for Part A were self-developed by the researcher. Part B measured the independent variable, which is the perceived advantages of flexible working arrangements, which has total of sixteen questions. Part C and D measured the dependent variables of organizational commitment (affective commitment, continuance commitment, and normative commitment) and work-family conflict. Part C covered the total of eighteen questions with each of the components (affective commitment, continuance commitment and normative commitment) covered by six items. As for Part D, there are a total of five questions for work-family conflict variable.

All the independent and dependent variables were measured using existing scales from previous studies. Hence, the validity and the reliability of the measuring scales for the questionnaire have already been tested and assured of. All of the scales for these variables were measured using a five-point Likert-type scale that ranged from “strongly disagree” (1) to “strongly agree” (5).

7. Data Analysis

A total of 130 were distributed through hardcopy handouts to all respondents who were the finance executives currently working in the six selected finance organizations located in both of manufacturing offices. However, only one hundred and twenty one questionnaires were collected back from the total of one hundred and thirty questionnaires that were distributed out. This gave a response rate of 93%. As a result, the usable percentage of the response rate was 87%.

7.1 Respondent's Demographic

Table 1 shows the demographic profiles of the respondents by gender, age, marital status, race, academic qualification, organizational tenure, current position, positional tenure and monthly salary.

The majority of the respondents are aged between 31-40 years old (55.8%) with 26.6 % aged 30 and below, followed by 16.8% aged between 41-50 years, and only 0.8% of the respondents that are aged more than 51 years old and above. For the gender demographic shown, the majority of the respondents are females (73.4%) while the minority are males (26.6%). When it comes to marital status, a majority of them, 54.9%, are married, followed by those who are single (44.3%) and only 0.8% are divorced. A huge majority of the respondents are Chinese (97.4%) and only 2.6% are Indians.

In term of their academic qualification, the majority of the respondents (65.5%) were holding a bachelor's degree; 15.9% have a postgraduate qualification; 14.2% are respondents with professional qualifications like ACCA, MICPA, CIMA; 3.5% have a diploma and 0.9% have an advanced diploma. Regarding organizational tenure, the majority of the respondents (32.8%) have worked in the manufacturing company for more than nine years, while 22.1% for 2 categories of those have work for one to three years and those have work between seven to nine years. Subsequently, it is followed by those that have worked for between four to six years (15.9%) and only 7.1% of those are those that have work less than one year.

More than half of the respondents (53.1%) possess senior positions, followed by 17.7% of the respondents who are in managerial positions, while 15.9% work in semi-senior positions, 11.5% are associates in junior positions and the minority (1.8%) work as directors. Almost half of the respondents (45.1%) work in their current position for only between one to three years, mainly because the manufacturing company is very supportive of job rotation opportunities among their employees as part of their career development initiatives within the organization. Most of the respondents (46%) earn more than RM5,000. The remaining percentages are 23% earning between RM3,001 to RM4,000, 12.4% earning between RM2,001 to RM3,003 and 18.6% earning between R4,001 to RM5,000.

Table 1. Demographic Profiles

Item	N	%
Gender		
Male	30	26.6
Female	83	73.4
Age (years old)		
Below 30	30	26.6
31-40	63	55.8
41-50	19	16.8
Above 50	1	0.8
Marital Status		
Single	50	44.3
Married	62	54.9
Ethnic		
Chinese	110	97.4
Indian	3	2.6
Academic Qualification		
Diploma & Advanced Diploma	5	4.4
Undergraduate Degree	74	65.5
Postgraduate Degree	18	15.9
Professional Qualification	16	14.2
Organizational Tenure (year)		
Below 1	8	7.1
1-3	25	22.1
4-6	18	15.9
7-9	25	22.1
Above 9	37	32.8
Position		
Associate/Junior	13	11.5
Semi-Senior	18	15.9
Senior	60	53.1
Managerial	20	17.7
Director	2	1.8
Positional Tenure (year)		
Below 1	27	23.9
1-3	51	45.1
4-6	19	16.8
7-9	9	8.1
Above 9	7	6.2
Monthly Salary (RM)		
2,000-3,000	14	12.4
3,001-4,000	26	23
4,100-5,000	21	18.6
Above 5,000	52	46.0

8. Correlation Analysis

Pearson's correlation analysis was used to test the relationship between the independent variables and dependent variables as depicted in Table 2. The relationship between flexible work arrangement and organizational commitment (as measured by affective commitment, continuance commitment and normative commitment) was investigated using the Pearson product-moment correlation coefficient. Preliminary analyses were performed to measure non violation of the assumptions of normality, linearity and homoscedasticity. There was a strong correlation between the variables, $r=.41$, $.33$ and $.37$, $n=113$, $p<.01$.

Meanwhile, the relationship between flexible working arrangements and work-family conflict was investigated using the Pearson product-moment correlation coefficient. Preliminary analyses were performed to measure non-violation of the assumptions of normality, linearity and homoscedasticity. There was a strong correlation between the variables, $r=.33$, $n=113$, $p<.01$.

Table 2. Pearson's Correlation Analysis

Variables	1	2	3	4	5
1 Flexible Working Arrangement	1				
2 Affective Commitment	0.41**	1			
3 Continuance Commitment	0.33**	0.30**	1		
4 Normative Commitment	0.37**	0.36**	0.06	1	
5 Work-Family Conflict	0.33**	0.22*	0.17	0.33**	1

** Correlation is significant at the 0.01 level (2-tailed)

- Correlation is significant at the 0.05 level (2-tailed)

9. Linear Regression Analysis

Linear regression analysis was used to measure the influence of the independent variables (flexible working arrangement) on the dependent variables (affective commitment, continuance commitment, normative commitment and work-family conflict). This analysis was employed to determine whether the developed hypotheses are supported or not for each of the organizational commitment. Thus, it could give better understanding on each hypothesis.

9.1 Regression Analysis on Affective Commitment

In Table 3, the R^2 value showed 17% for the dependent variable of affective commitment, which was explained by flexible working arrangements. This means that 83% of the variance for affective commitment was explained by other unknown additional variables that have not been explored. The regression model ($F=22.77$, $p < .01$) was proven to be a significant model due to the F ratio being significant in predicting affective commitment. Overall, the F ratio result presented that the combination of flexible working arrangements was a good fit in predicting affective commitment. Looking at the individual predictor, flexible working arrangement ($\beta=.41$, $p<.05$) was a significant predictor for affective commitment. This explained that flexible working arrangement was positively related to affective commitment. Therefore, as a result, both H1 was supported.

Table 3. Regression Results for Affective Commitment

Independent Variables	Standardized Coefficients (β)
Flexible Working Arrangement	0.41**
R^2	0.17
Adjusted R^2	0.16
F – change	22.77

* $p < .10$, ** $p < .05$, *** $p < .01$

9.2 Regression Analysis on Continuance Commitment

With continuance commitment as a dependent variable in Table 4, the R^2 value showed 11% for the dependent variable of continuance commitment, which was explained by flexible working arrangements. This means that 89% of the variance for continuance commitment was explained by other unknown additional variables that have not been explored. The regression model ($F=13.12$, $p<.01$) was proven to be a significant model due to the F ratio being significant in predicting continuance commitment. Overall, the F ratio result presented that the combination of flexible working arrangements was a good fit in predicting continuance commitment. For an individual predictor, flexible working arrangement ($\beta=.33$, $p<.05$) was found to be significantly related to continuance commitment. This

explained that flexible working arrangement was positively related to continuance commitment. Therefore, as a result, H1b was supported.

Table 4. Regression Results for Continuance Commitment

Independent Variables	Standardized Coefficients (β)
Flexible Working Arrangement	0.33**
R^2	0.11
Adjusted R^2	0.10
F – change	13.12

* $p < .10$, ** $p < .05$, *** $p < .01$

9.3 Regression Analysis on Normative Commitment

Table 5 showed that the R^2 value of 13% for the dependent variable of normative commitment was explained by flexible working arrangement. This means that 87% of the variance for normative commitment was explained by other unknown additional variables that have not been explored. The regression model ($F=17.07$, $p<.01$) was proven to be a significant model due to the F ratio being significant in predicting normative commitment. Overall, the F ratio result presented that the combination of flexible working arrangement was a good fit in predicting normative commitment. Looking at the individual predictor, flexible working arrangement ($\beta=.37$, $p<.05$) was a significant predictor for normative commitment. This explained that flexible working arrangement was positively related to normative commitment. Therefore, as a result, H1c was supported.

Table 5. Regression Results for Normative Commitment

Independent Variables	Standardized Coefficients (β)
Flexible Working Arrangement	0.37**
R^2	0.13
Adjusted R^2	0.13
F – change	17.07

* $p < .10$, ** $p < .05$, *** $p < .01$

9.4 Regression Analysis on Work-Family Conflict

With work-family conflict as dependent variable, the R^2 value in Table 6 revealed that 11% of the variance for work-family conflict was explained by flexible working arrangements. This means that 89% of the variance for work-family conflict was explained by other unknown additional variables that have not been explored. The regression model ($F=13.10$, $p<.01$) was proven to be a significant model due to the F ratio being significant in predicting work-family conflict. Overall, the F ratio result presented that the combination of flexible working arrangement was a good fit in predicting work-family conflict. Looking at the individual predictor, flexible working arrangement ($\beta=.33$, $p<.05$) was a significant predictor for work-family conflict. This explained that flexible working arrangement was positively related to work-family conflict. Therefore, as a result H2 was supported.

Table 6. Regression Results for Work-Family Conflict

Independent Variables	Standardized Coefficients (β)
Flexible Working Arrangement	0.33**
R^2	0.11
Adjusted R^2	0.10
F – change	13.10

* $p < .10$, ** $p < .05$, *** $p < .01$

In summary, all the four hypotheses were supported as depicted in Table 7.

Table 7. Summary of Hypotheses Results

Hypotheses		Results
H1a	Flexible working arrangement is positively related to affective commitment.	Supported
H1b	Flexible working arrangement is positively related to continuance commitment.	Supported
H1c	Flexible working arrangement is positively related to normative commitment.	Supported
H2	Flexible working arrangement is positively related to work-family conflict.	Supported

10. Discussion

With inadequate empirical research on flexible working arrangement and organizational commitment and work-family conflict in the manufacturing industry in Malaysia, the present paper is an attempt in the said direction. As stated earlier, three hypotheses were proposed to examine the relationships between independent variable and dependent variables and the research findings are discussed in below.

10.1 The Relationship between Flexible Working Arrangement and Organizational Commitment

Apparently, results have indicated that there is consistent support for flexible working arrangements and organizational commitment in the suggested hypotheses. In other words, flexible working arrangement is significantly related to organizational commitment in which their relationship is in a positive direction. This is explained in the situation where finance executives in a manufacturing company reported higher levels of organizational commitment if they were working for any organization that they believed included flexible work hours in their psychological contract.

Specifically, the existence of flexible work hour programs or policies is the representative of the organizational support that contributes to a supportive working culture in the organization. Thus, both perceived flexibility and supportive work life policies are considered the best predictors of an employee's organizational commitment. It is also noteworthy that the existence of the flexible work policies being offered to employees was significantly associated with higher organizational commitment, regardless of whether or not the employee had actually utilized the program. This means that the perception of having the flexible work program or policies is a critical factor to show that the organization is willing to adapt to employee needs.

The findings showed that an increase in perceived support by managers or organizations would lead to an increase in affective commitment among the employees. With regard to perceived family-supportive work culture and its association with affective commitment, the findings are consistent with the previous research of Haar and Spell (2004). In other words, employees who receive support to manage their work and family lives are more committed to their organizations and are more likely to stay in their organizations.

Although this paper does not specifically investigate how the family-responsive policies, such as flexible work hours, would bring differential impact on the organizational commitment of women and men, future research should examine on how the flexible work hours policies would bring differential impact to women, since women may be more sensitive as well as possess a greater appreciation for the availability of family-responsive policies due to their dual-roles and responsibilities as professionals and care-providers.

10.2 The Relationship between Flexible Working Arrangement and Work-Family Conflict

The results are in agreement with those of Beauvais and Kowalski (1993) who explained how individuals who perceived family-supportive work culture among their organizational culture are most likely to experience lower levels of work-family conflict as per the suggested hypothesis. The availability and implementation of such family-responsive policies does represent an organizational culture which is supportive of family domain and shows sensitivity to career-family demands.

To understand why and how flexible working arrangement can influence individual work-related attitudes and behaviors, it is important to examine how flexibility can affect different aspects of work-family conflict. For example, there may be different implications of the effects of flexible working arrangement on time-related strains or emotional conflict such as the general sentiment of how 'not being able to do two things at the same time may impact differently from feeling bad about it'.

However, Kossek and Ozeki (1999) argued that more studies examining work-family conflict variable are often neglected, whereby flexible working arrangement may relate more to other organizational outcomes like job satisfaction, productivity performance, employee retention, employees absenteeism and many others. Therefore, as Kossek and Ozeki (1999) suggested, there is a need to perform more longitudinal research to understand the impact of flexible working arrangement on work-family conflict. This may help to extend researchers' understanding of how the flexible work policies would impact individual and organizational outcome, as the results may vary for different groups of employees and this factor needs to be taken into consideration for research.

11. Managerial Implications

The results may provide the practical implications for the management team to understand the employee's commitment and work-family conflict level and strategize to implement suitable family responsive policies for their employees. First, the implementing of flexible work arrangement policies is important to employees and is positively associated with the organization's desired outcomes of high organizational commitment. The results clearly showed that the majority of survey respondents are employees that have been working in Penang for more than nine years. Thus, the results suggested that flexible work policies is one of the motivators that management or human resource departments can implement to increase the level of employee commitment, especially for female employees that possess dual roles and responsibilities. In order to achieve the effectiveness of flexible working arrangement policies, managers play an important role in communicating, implementing and managing the flexibility options within organizational cultures. With this supportive perception from management, there is a greater tendency for employees to feel happy which can lead to an increased likelihood to stay committed in the organization.

Second, the presence of flexible working arrangement policies is significantly associated with lower work-family conflict among employees from the result. At a macro level, flexible working arrangement implementation creates a more environmentally friendly workplace with less traffic congestion and better family management. Employees are more satisfied with their job and experience a greater work-life balance when they have the ability to control their working time, are flexible to work remotely and to choose the pace of work. Even though this paper showed a strong relationship among the variables where they were associated positively, it is recommendable that managers should engage openly with their employees by letting them make use of the flexible working arrangement policies. Thus, organizations or human resource departments are advised to show that they value the hard-work of company employees, and care about their well-being by making significant investments. For example, they should look into the possibility of developing and providing work-family programs and family-friendly practices to assist employees in managing the conflict between work and family roles.

In addition, it is hoped that these results would encourage further investigations and applications of family responsive policies in organizations. This would contribute and help organizations to face the challenges of retaining talented, hard-working and committed employees.

12. Conclusion

To conclude, the present paper revealed that flexible working arrangements are a strong predictor for increasing employee's organizational commitment and lower work-family conflict. Hence, the organizations in Malaysia should emphasize the importance of flexible working arrangement and attempt to offer a flexible work environment that supports flexible working arrangement to meet the needs of their employees. Suffice it to say, high organizational commitment and lower work-family conflict are vital aspects that many organization should further develop to achieve the organizational objectives and as part of supporting Malaysia's vision to grow from an upper middle income country to a high income country by 2020.

References

- Adams, G. A., & Jex, S.M. (1999). Relationships between time management, control, work-family conflict, and strain. *Journal of Occupational Health Psychology, 4*, 72-77. <http://dx.doi.org/10.1037/1076-8998.4.1.72>
- Adebayo, D.O. (2006). The moderating effect of self-efficacy on job insecurity and organizational commitment among Nigerian public servants. *Journal of Psychology in Africa, 16*(1), 35-43.
- Allen, T. D., & Shockley, K. (2006). *Flexible work arrangements: Help or hype?* Paper presented at the Families and Health Conference, Provo, Utah.

- Almer, E., & Kaplan, S. (2002). The effects of flexible work arrangements on stressors, burnout and behavioural job outcomes in public accounting. *Behavioral Research in Accounting*, 14, 1-34. <http://dx.doi.org/10.2308/bria.2002.14.1.1>
- Aminah, A. (2007). Family-friendly employment policy in the Malaysian Government and selected private organizations. *The Journal of Global Business Management*, 3, 128-135.
- Anderson, S. E., Coffey, B. S., & Byerly, R. T. (2002). Formal organizational initiatives and informal workplace practice: Links to work–family conflict and job-related outcomes. *Journal of Management*, 173, 1-24.
- Baltes, B. B., Briggs, T. E., HuV, J. W., Wright, J. A., & Neuman, G. A. (1999). Flexible and compressed workweek schedules: A meta-analysis of their effects on work-related criteria. *Journal of Applied Psychology*, 84, 496–513. <http://dx.doi.org/10.1037/0021-9010.84.4.496>
- Barnett, R. C., & Hall, D. T. (2001). How to use reduced hours to win the war for talent. *Organizational Dynamics*, 29(3), 192–210. [http://dx.doi.org/10.1016/S0090-2616\(01\)00024-9](http://dx.doi.org/10.1016/S0090-2616(01)00024-9)
- Barnett, R. C., Gareis, K. C., & Brennan, R. T. (1999). Fit as a mediator of the relationship between work hours and burnout. *Journal of Occupational Health Psychology*, 4(4), 307–317. <http://dx.doi.org/10.1037/1076-8998.4.4.307>
- Batt, R., & Valcour, P.M. (2003). Human resources practices as predictors of work– family outcomes and employee turnover. *Industrial Relations*, 42, 189-220. <http://dx.doi.org/10.1111/1468-232x.00287>
- Beauvais, L. L., & Kowalski, K. B. (1993). Predicting work/family conflict and participation in family-supportive work behaviors: A test of two competing theories. Paper presented at the Academy of Management, Atlanta, GA.
- Becker, H.S. (1960). Notes on the concept of commitment. *The American Journal of Sociology*. 66, 32-40. <http://dx.doi.org/10.1086/222820>
- Bond, J.T., Thompson, C.A., Galinsky, E., & Prottas, D. (2002). *Highlights of the National Study of the Changing Workforce*. New York: Families and Work Institute.
- Boyar, S.L., Maertz, C.P. Jr., Mosley, D.C., & Carr, J.C. (2008). The impact of work/family demand on work family conflict. *Journal of Managerial Psychology*, 23(3), 215-235. <http://dx.doi.org/10.1108/02683940810861356>
- Breakwell, G.M., Hammond, S., & Fife-Schaw, C. (1995). *Research methods in psychology*. London: Sage.
- Briscoe, J. P., & Finkelstein, L. M. (2009). The new career and organizational commitment: Do boundaryless and protean attitudes make a difference? *Career Development International*, 14, 242-260. <http://dx.doi.org/10.1108/13620430910966424>
- Cully, M., Woodland, S., O'Reilly, A., & Dix, G. (1999). *Small Business Employment Relations' in Workplace Employee Relations Survey*, London: Routledge.
- Dex, S., & Smith, C. (2002). *The Nature and Pattern of Family-Friendly Employment Policies in Britain*. Bristol: Policy Press and Joseph Rowntree Foundation.
- Dunham, R., Pierce, J., & Casaneda, M. (1987). Alternative work schedules: two field quasi experiments. *Personnel Psychology*, 40, 215–242. <http://dx.doi.org/10.1111/j.1744-6570.1987.tb00602.x>
- Eby, L.T., Casper, W.J., Lockwood, A., Bordeaux, C., & Brinley, A. (2005). Work and family research in IO/OB: content analysis and review of the literature (1989–2002). *Journal of Vocational Behavior*, 66, 124-197. <http://dx.doi.org/10.1016/j.jvb.2003.11.003>
- Edimansyah, B.A., Rusli, N., Naing, L., Mohamed Rusli, A., Winn, T., & Tengku Mohamed Ariff, R.H. (2008). Self-perceived depression, anxiety, stress and their relationships with psychosocial job factors in male automotive assembly workers. *Industrial Health*, 46(1), 90-100. <http://dx.doi.org/10.2486/indhealth.46.90>
- Friedman, S. F., & Greenhaus, J. H. (2000). *Work and Family—Allies or Enemies*. New York: Oxford University Press. <http://dx.doi.org/10.1093/acprof:oso/9780195112757.001.0001>
- Frone, M. R., Russell, M., & Cooper, M. L. (1992). Antecedents and outcomes of work–family conflict: Testing a model of the work–family interface. *Journal of Applied Psychology*, 77(1), 65-78. <http://dx.doi.org/10.1037/0021-9010.77.1.65>
- Frye, N.K., & Breaugh, J. (2004). Family friendly policies, supervisor support, work family conflict, family work conflict and satisfaction: a test of a conceptual model. *Journal of Business and Psychology*, 19, 197-220.

<http://dx.doi.org/10.1007/s10869-004-0548-4>

- Galinsky, E., & Johnson, A. A. (1998). *Reframing the Business Case for Work–Life Initiatives*. New York: Families and Work Institute.
- Galinsky, E., Bond, J. T., & Friedman, D. E. (1996). The role of employers in addressing the needs of employed parents. *Journal of Social Issues*, 52, 111-136. <http://dx.doi.org/10.1111/j.1540-4560.1996.tb01582.x>
- Galinsky, E., Bond, T., & Friedman, D. E. (1993). *National study of the changing workforce*. New York: Families and Work Institute.
- Ghani, R. A., Nordin, F., & Mamat, L. (2004). Organizational commitment among the academic staff in the Distance Education Program. *The International Journal of Education Development*, 1, 29-43.
- Glass, J., & Estes, S. (1997). The Family Responsive Workplace. *Annual Review of Sociology*, 23, 289-313. <http://dx.doi.org/10.1146/annurev.soc.23.1.289>
- Glass, J., & Finley, A. (2002). Coverage and effectiveness of family-responsive workplace policies. *Human Resource Management Review*, 12, 313-337. [http://dx.doi.org/10.1016/S1053-4822\(02\)00063-3](http://dx.doi.org/10.1016/S1053-4822(02)00063-3)
- Golden, L. (2001). Flexible work schedules. Which workers get them? *American Behavioral Scientist*, 44(7), 1157-1178. <http://dx.doi.org/10.1177/00027640121956700>
- Goldenhar, D. (2003). *The benefits of flexible work arrangements*. New York: Advancing Women Professional and The Jewish Community.
- Greenhaus, J. H., & Powell, G. N. (2003). When work and family collide: Deciding between competing role demands. *Organizational Behavior and Human Decision Processes*, 90(2), 291-303. [http://dx.doi.org/10.1016/S0749-5978\(02\)00519-8](http://dx.doi.org/10.1016/S0749-5978(02)00519-8)
- Greenhaus, J.H., & Beutell, N.J. (1985). Sources of conflict between work and family roles. *The Academy of Management Review*, 10(1), 76-88.
- Grover, S. L., & Crooker, K. J. (1995). Who appreciates family-responsive human resource policies: The impact of family-friendly policies on the organizational attachment of parents and non-parents. *Personnel Psychology*, 48, 271-288. <http://dx.doi.org/10.1111/j.1744-6570.1995.tb01757.x>
- Haar, J.M., & Spell, C.S. (2004). Programme Knowledge and Value of Work-Family Practice and Organizational Commitment. *International Journal of Human Resource Management*, 15(6), 1040-1055. <http://dx.doi.org/10.1080/09585190410001677304>
- Halpern, D. F. (2005). How time-flexible work policies can reduce stress, improve health, and save money, Stress and Health, *Journal of the International Society for the Investigation of Stress*, 21, 157-168. <http://dx.doi.org/10.1002/smi.1049>
- Hammer, L. B., Allen, E., & Grigsby, T. D. (1997). Work–family conflict in dual-earner couples: Within individual and crossover effects of work and family. *Journal of Vocational Behavior*, 50, 185-203. <http://dx.doi.org/10.1006/jvbe.1996.1557>
- Hammer, L.B., Neal, M.B., Newsom, J.T., Brockwood, K.J., & Colton, C.L. (2005). A longitudinal study of the effects of dual-earner couples' utilization of family-friendly workplace supports on work and family outcomes. *Journal of Applied Psychology*, 90(4), 799-810. <http://dx.doi.org/10.1037/0021-9010.90.4.799>
- Harris, L., & Foster, C. (2005). *Small, Flexible and Family Friendly – Work Practices in Service Sector Businesses*. London: Department of Trade and Industry, Employment Relations Research Series No. 47.
- Hill, E. J., Hawkins, A. J., & Miller, B. C. (1996). Work and family in the virtual office. Perceived influences of mobile telework. *Family Relations*, 45(3), 293-301. <http://dx.doi.org/10.2307/585501>
- Hill, E. J., Yang, C., Hawkins, A. J., & Ferris, M. (2004). A cross-cultural test of the work–family interface in 48 countries. *Journal of Marriage and Family*, 66, 1300-1316. <http://dx.doi.org/10.1111/j.0022-2445.2004.00094.x>
- Hill, E.J., Grzywacz, J.G., Allen, S., Blanchard, V.L., Matz-Costa, C., Shulkin, S., & Pitt-Catsouphes, M. (2008). Defining and conceptualizing workplace flexibility. *Community, Work, & Family*, 11(2), 149-163. <http://dx.doi.org/10.1080/13668800802024678>
- Hogarth, T., Hasluck, C., & Pierre, G. (2000). *Work-Life Balance 2000: Baseline Study of Work-Life Balance Practices in Great Britain*. London: Dfee.

- Johnson, R. E., Chang, D. C. H., & Yang, L. Q. (2010). Commitment and motivation at work: The relevance of employee identity and regulatory focus. *The Academy of Management Review*, 35, 226-245. <http://dx.doi.org/10.5465/AMR.2010.48463332>
- Ketchand, A. A., & Strawser, J. R. (2001). Multiple dimensions of organizational commitment: Implications for future accounting research. *Behavioral Research in Accounting*, 13, 221-251. <http://dx.doi.org/10.2308/bria.2001.13.1.221>
- Kossek, E. E., & Ozeki, C. (1999). Bridging the work–family policy and productivity gap: A literature review. *Community, Work and Family*, 2(1), 7–32. <http://dx.doi.org/10.1080/13668809908414247>
- Kossek, E., & Ozeki, C. (1998). Work–family conflict policies and the job–life satisfaction relationship. *Journal of Applied Psychology*, 83, 139-149. <http://dx.doi.org/10.1037/0021-9010.83.2.139>
- Lapierre, L., & Allen, T. (2006). Work-supportive family, family-supportive supervision, use of organizational benefits and problem-focused coping: implications for work– family conflict and employee well-being. *Journal of Occupational Health Psychology*, 11, 169-181. <http://dx.doi.org/10.1037/1076-8998.11.2.169>
- Lee, C. M., & Duxbury, L. (1998). Employed parents' support from partners, employers, and friends. *The Journal of Social Psychology*, 138(3), 303-322. <http://dx.doi.org/10.1080/00224549809600383>
- Lewis, S., Smithson, J., Cooper, C. L., & Dyer, J. (2002). *Flexible Futures: Flexible Working and Work-Life Integration (Report on Phase Two)*. London: Institute of Chartered Accountants in England and Wales.
- Lim, V.K.G., & Teo, T.S.H. (2000). To work or not to work at home: An empirical investigation of factors affecting attitudes towards teleworking. *Journal of Managerial Psychology*, 15(6), 560-566. <http://dx.doi.org/10.1108/02683940010373392>
- Lyons, S. (2011). *Investigating how motivation affects generation Y's relatedness in the workplace*. Retrieved from <http://seanlyons.ca/wpcontent/uploads/2012/01/Motivation-and-Relatedness.pdf>
- Madsen, S. (2006). Work and family conflict: can home based teleworking make a difference? *International Journal of Organization Theory and Behavior*, 9, 307-350.
- Manshor, A.T., Fontaine, R., & Chong, S.C. (2003). Occupational stress among managers: a Malaysian survey. *Journal of Managerial Psychology*, 18(6), 622-628. <http://dx.doi.org/10.1108/02683940310494412>
- Marks, S.R. (1977). Multiple roles and role strain: Some notes on human energy, time and commitment. *American Sociology*, 80(5), 1212-1219. <http://dx.doi.org/10.2307/2094577>
- Maxwell, G., Rankine, L., Bell, S., & MacVicar, A. (2007). The incidence and impact of flexible working arrangements in smaller businesses. *Employee Relations*, 29, 138-152. <http://dx.doi.org/10.1108/01425450710719987>
- Meyer, J. P., & Allen, N. J. (1991). A three-component conceptualization of organizational commitment. *Human Resource Management Review*, 1, 61-89. [http://dx.doi.org/10.1016/1053-4822\(91\)90011-Z](http://dx.doi.org/10.1016/1053-4822(91)90011-Z)
- Meyer, J. P., & Allen, N. J. (1997). *Commitment in the workplace: Theory, research, and application*. Newbury Park, CA: Sage.
- Meyer, J. P., & Herscovitch, L. (2001). Commitment in the workplace: Toward a general model. *Human Resource Management Review*, 11, 299-326. [http://dx.doi.org/10.1016/S1053-4822\(00\)00053-X](http://dx.doi.org/10.1016/S1053-4822(00)00053-X)
- Meyer, J. P., Paunonen, S. V., Gellatly, I. R., GoYn, R. D., & Jackson, D. N. (1989). Organizational commitment and job performance: It's the nature of the commitment that counts. *Journal of Applied Psychology*, 74, 152-156. <http://dx.doi.org/10.1037/0021-9010.74.1.152>
- Meyer, J. P., Stanley, D. J., Herscovitch, L., & Topolnytsky, L. (2002). Affective, continuance, and normative commitment to the organization: A meta-analysis of antecedents, correlates, and consequences. *Journal of Vocational Behavior*, 61, 20-52. <http://dx.doi.org/10.1006/jvbe.2001.1842>
- Meyer, J., & Allen, N. (1984). Testing the side-bet theory of organizational commitment: Some methodological considerations. *Journal of Applied Psychology*, 69, 372-378. <http://dx.doi.org/10.1037/0021-9010.69.3.372>
- Morrow, P. (1993). *The Theory and Measurement of Work Commitment*. CT: JAL, Greenwich.
- Mowday, R., Steers, R., & Porter, L. (1979). The measurement of organizational commitment. *Journal of Vocational Behavior*, 14, 224-247. [http://dx.doi.org/10.1016/0001-8791\(79\)90072-1](http://dx.doi.org/10.1016/0001-8791(79)90072-1)

- Netemeyer, R. G., Boles, J. S., & McMurrian, R. (1996). Development and validation of work–family conflict and work–family conflict scales. *Journal of Applied Psychology*, 81, 400-410. <http://dx.doi.org/10.1037/0021-9010.81.4.400>
- Nijhof, W.J., De Jong, M.J., & Beukhof, G. (1998). Employee commitment in changing organizations: an exploration. *J. Eur. Ind. Train*, 22, 243-248. <http://dx.doi.org/10.1108/03090599810224701>
- O'Reilly, III, C., & Chatman, J. (1986). Organizational Commitment and Psychological Attachment: The Effects of Compliance, Identification and Internalization on Prosocial Behavior. *Journal of Applied Psychology*, 71(3), 492-499. <http://dx.doi.org/10.1037/0021-9010.71.3.492>
- Perrin, Towers. (1994). *Work/life programs: Supporting a new employer/employee deal*. A Towers Perrin Survey Report. Boston: Towers Perrin.
- Pierce, J.L., & Newstrom, J.W. (1982). Employee responses to flexible work schedules: an inter-organization, intersystem comparison. *Journal of Management*, 8, 9-25. <http://dx.doi.org/10.1177/014920638200800101>
- Pierce, J.L., & Newstrom, J.W. (1980). Toward a conceptual clarification of employee responses to flexible working hours: a work adjustment approach. *Journal of Management*, 6, 117-134. <http://dx.doi.org/10.1177/014920638000600202>
- Pitt-Catsoupes, M., Kossek, E. E., & Sweet, S. (2006). *The Handbook Of Work-Family: Multi-Disciplinary Perspectives, Methods, And Approaches*. Mahwah, N.J.: Lawrence Erlbaum Associates(LEA) Press.
- Rau B.L., & Hyland, M. M. (2002). Role conflict and flexible work arrangements: The effects on applicant attraction. *Personnel Psychology*, 55(1), 111-136. <http://dx.doi.org/10.1111/j.1744-6570.2002.tb00105.x>
- Reichers, A. (1985). A review and reconceptualization of organizational commitment. *The Academy of Management Review*, 10(3), 465-476.
- Richman, A. (2006). Everyone wants an engaged workforce: How can you create it? *Workspan*, 36-39.
- Roehling, P.V., Roehling, M.V., & Moen, P. (2001). The relationship between work-life policies and practices and employment loyalty: A life course perspective. *Journal of Family and Economic Issues*, 22, 141–70. <http://dx.doi.org/10.1023/A:1016630229628>
- Salami, S.O. (2008). Demographic and psychological factors predicting organizational commitment among industrial workers. *Anthropologist*, 10(1), 31-38.
- Subramaniam, G., & Silvaratnam, D. P. (2010). Family friendly policies in Malaysia: Where are we? *Journal of International Business Research*, 9(1), 43-55.
- Thomas, L.T., & Ganster, D.C. (1995). Impact of family supportive work variables on work–family conflict and strain: a control perspective. *Journal of Applied Psychology*, 80, 6-15. <http://dx.doi.org/10.1037/0021-9010.80.1.6>
- Thompson, C., Beauvais, L., & Lyness, K.S. (1999). When work–family benefits are not enough: the influence of work–family culture on benefit utilization, family attachment and work–family conflict. *Journal of Vocational Behavior*, 54, 392-415. <http://dx.doi.org/10.1006/jvbe.1998.1681>
- Thompson, C.A., Beauvais, L.L., & Allen, T.D. (2006). Work and Family from an industrial/organizational psychology perspective, In M. Pitt-Catsoupes, E.E. Kossek, & S. Sweet (Eds.), *The Work and Family Handbook: Multi-Disciplinary Perspectives and Approaches*, Mahwah: Lawrence Erlbaum, 283-307.
- White, M., Hill, S., McGovern, P., Mills, C., & Smeaton, D. (2003). High-Performance' Management Practices, Working Hours and Work-Life Balance. *British Journal of Industrial Relations*, 41(2), 175-195. <http://dx.doi.org/10.1111/1467-8543.00268>
- Younis, A., Zulfiqar, S., Arshad, H., & Imran, M. (2011). Struggle to juggle gender and work life balance. *Interdisciplinary Journal of Contemporary Research in Business*, 3(4), 514-531.